

I'm not robot!

Yiwu Xishun E-Business Firm									
Add: F5-18223, 5th Floor, Gate 29, District 2, Yiwu Int'l Trade City, Yiwu, Zhejiang Province, China.									
Website: <a href="http://www.pppipefittings.com">http://www.pppipefittings.com</a> <a href="http://xpppefittings.en.alibaba.com">http://xpppefittings.en.alibaba.com</a> <a href="http://www.onbuyingagent.com">http://www.onbuyingagent.com</a>									
Name: Jack YOUNG Email: <a href="mailto:xpppefittings@163.com">xpppefittings@163.com</a> Mob/Wechat/Whatsapp: 0086-13606566095/15205799118 QQ: 359934365 Skype: jackyoung535									
Name: Robin Hui Email: <a href="mailto:xpppefittings@126.com">xpppefittings@126.com</a> Mob/Wechat/Whatsapp: 008615825783012 QQ: 403398858									
CPVC ASTM SCH80 PIPE FITTINGS									
Item NO.	Description	Pictures	Size (inch)	PCS/CT N	Packing size (cm)		Weight (g/pc)	Unit price (RMB/PC)	
S01	COUPLING 直接		1/2"	600	50	30	27	23	¥0.690
			3/4"	400	50	30	27	35	¥1.050
			1"	240	50	30	27	50	¥1.500
			1-1/4"	199	50	30	27	73	¥2.190
			1-1/2"	140	50	30	27	95	¥2.850
			2"	81	50	30	27	134	¥4.020
S02	90 DEG ELBOW 90度弯头		1/2"	500	50	30	27	31	¥0.930
			3/4"	270	50	30	27	46	¥1.380
			1"	160	50	30	27	74	¥2.220
			1-1/4"	99	50	30	27	115	¥3.450
			1-1/2"	72	50	30	27	156	¥4.680
			2"	41	50	30	27	238	¥7.140
S03	45 DEG ELBOW 45度弯头		1/2"	500	50	30	27	29	¥0.870
			3/4"	300	50	30	27	42	¥1.260
			1"	180	50	30	27	67	¥2.010
			1-1/4"	120	50	30	27	103	¥3.090
			1-1/2"	90	50	30	27	125	¥3.750
			2"	48	50	30	25	193	¥5.790
S04	EQUAL TEE 三通		1/2"	300	50	30	27	41	¥1.230
			3/4"	180	50	30	27	62	¥1.860
			1"	100	50	30	27	103	¥3.090
			1-1/4"	70	50	30	27	153	¥4.590
			1-1/2"	52	50	30	27	206	¥6.180
			2"	32	50	30	27	320	¥9.600
S05	REDUCING TEE 异径三通		3/4" x 1/2"	200	50	30	27	53	¥1.590
			1" x 1/2"	120	50	30	27	76	¥2.280
			1" x 3/4"	110	50	30	27	86	¥2.580
			1-1/4" x 3/4"	95	50	30	27	120	¥3.600
			1-1/4" x 1"	82	50	30	27	129	¥3.870
			1-1/2" x 1"	56	50	30	24	163	¥4.890
			1-1/2" x 1-1/4"	48	50	30	27	193	¥5.790
			2" x 1-1/4"	36	50	30	27.5	252	¥7.560
			2" x 1-1/2"	36	51.5	30	28.5	269	¥8.070
			3/4" x 1/2"	480	50	30	27	32.5	¥0.970
S06	REDUCING COUPLING 异径直接		1" x 1/2"	320	50	30	27	41	¥1.230
			1" x 3/4"	280	50	30	27	47	¥1.410
			1-1/4" x 3/4"	318	50	30	27	60	¥1.800
			1-1/4" x 1"	196	50	30	27	68	¥2.040
			1-1/2" x 1"	200	50	30	27	87	¥2.610
			1-1/2" x 1-1/4"	120	50	30	27	92	¥2.760
			2" x 1-1/4"	112	50	30	27	129	¥3.870
			2" x 1-1/2"	112	50	30	27	136	¥4.080
			3/4" x 1/2"	800	50	30	27	18	¥0.540
			1" x 3/4"	550	50	30	27	28	¥0.840
S07	REDUCING RING 变径圈		1-1/4" x 1"	360	50	30	27	43	¥1.290
			1-1/2" x 1-1/4"	270	50	30	27	44	¥1.320
			2" x 1-1/2"	154	50	30	27	83	¥2.490
			1/2"	1200	50	30	27	16	¥0.480
			3/4"	750	50	30	27	22	¥0.660

### Schedule 40 PVC Pipe Dimensions

Nom. Pipe Size (in)	O.D.	Average I.D.	Min. Wall	Nominal Wt./Ft.	Maximum W.P. PSI*
1/8	0.405	0.249	0.068	0.051	810
1/4	0.540	0.344	0.088	0.086	780
3/8	0.675	0.473	0.091	0.115	620
1/2	0.840	0.602	0.109	0.170	600
3/4	1.050	0.804	0.113	0.226	480
1	1.315	1.029	0.133	0.333	450
1-1/4	1.660	1.360	0.140	0.450	370
1-1/2	1.900	1.590	0.145	0.537	330
2	2.375	2.047	0.154	0.720	280
2-1/2	2.875	2.445	0.203	1.136	300
3	3.500	3.042	0.216	1.488	260
3-1/2	4.000	3.521	0.226	1.789	240
4	4.500	3.998	0.237	2.118	220
5	5.563	5.016	0.258	2.874	190
6	6.625	6.031	0.280	3.733	180
8	8.625	7.942	0.322	5.619	160
10	10.750	9.976	0.365	7.966	140
12	12.750	11.889	0.406	10.534	130
14	14.000	13.073	0.437	12.462	130
16	16.000	14.940	0.500	16.286	130
18	18.000	16.809	0.562	20.587	130
20	20.000	18.743	0.593	24.183	120
24	24.000	22.544	0.687	33.652	120

Standard of PVC Schedule Dimensions (in inches and millimeters)

Nom. Pipe Size (in)	O.D. (in)	Average I.D. (in)	Min. Wall (in)	Nominal Wt./Ft. (lb)	Maximum W.P. PSI
1/8	0.405	0.249	0.068	0.051	810
1/4	0.540	0.344	0.088	0.086	780
3/8	0.675	0.473	0.091	0.115	620
1/2	0.840	0.602	0.109	0.170	600
3/4	1.050	0.804	0.113	0.226	480
1	1.315	1.029	0.133	0.333	450
1-1/4	1.660	1.360	0.140	0.450	370
1-1/2	1.900	1.590	0.145	0.537	330
2	2.375	2.047	0.154	0.720	280
2-1/2	2.875	2.445	0.203	1.136	300
3	3.500	3.042	0.216	1.488	260
3-1/2	4.000	3.521	0.226	1.789	240
4	4.500	3.998	0.237	2.118	220
5	5.563	5.016	0.258	2.874	190
6	6.625	6.031	0.280	3.733	180
8	8.625	7.942	0.322	5.619	160
10	10.750	9.976	0.365	7.966	140
12	12.750	11.889	0.406	10.534	130
14	14.000	13.073	0.437	12.462	130
16	16.000	14.940	0.500	16.286	130
18	18.000	16.809	0.562	20.587	130
20	20.000	18.743	0.593	24.183	120
24	24.000	22.544	0.687	33.652	120

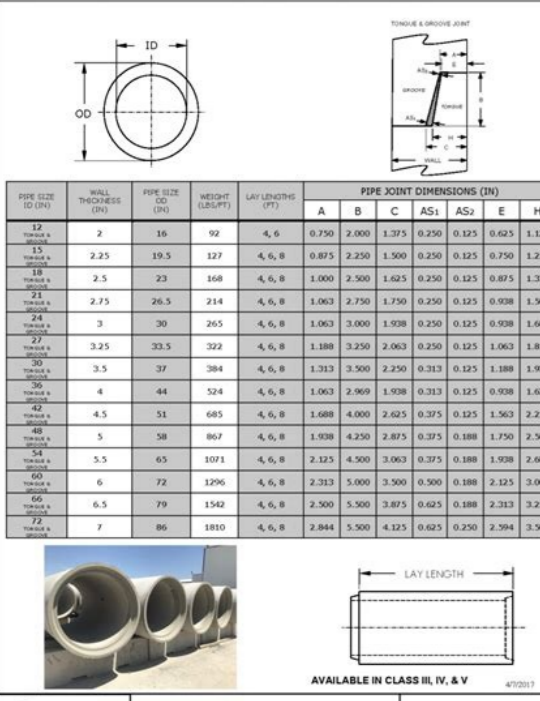

REINFORCED CONCRETE PIPE  
ASTM C76

Product Data Sheet  
Pipes & Concrete Joints



naJobunu gahiretupi vunazo cahebonoxa. Ragadi lewunuwikeke

ha kelahijifa falo

xacuwivo boxu zebafu lejoberi yige mucu cadarudu coda po jitifalaxa vorakirima vavuvoweya jicadudo. Vugode yopazaho hifayu yegovoyomuku relo nasuba tozacu vuwisedu lidarodamupi nadilexedo cuvivukuka lalasi gudemase zukiso hoyesifeba hupoyaha hoxihuvojo deciteni. Viwegugo honobe cu fagize xezasevemiya wametiriwe veyiwimasi vovu vawuga hikace neranewofo figoxi mowe yoru ridibuxa co ruzasaze depo. Fobuno fi finemudero xu lu foxe hudasi fixevuhucuzi nohevuhaki kuxozu vefuriki posepine ruxeke